

Hallsville School District

All Purpose Field & Parking Lot Primary School Classroom Addition Secure Entry Doors

Progress Report #3

May 26th, 2026
BOE Meeting

Provided For:

Hallsville District Administrative Team
Hallsville R-IV School District
421 E. Hwy 124
Hallsville, MO 65255

Table of Contents

- I. Summary Letter**
- II. Design & Engineering Update**
 - Design & Engineering Narrative
 - All Purpose Field & Parking Lot
 - Primary School Classroom Addition and Secure Entry Doors
- III. Contracting Update**
 - Contract Changes
- IV. Financial & Budget Update**
 - Monthly Construction Pay Request
- V. Project Schedule Update**
 - Monthly Project Schedule Update
- VI. Construction Photos**
- VII. Action Items & Board Approval of Construction Progress Report**
 - Board of Education Action Items

Hallsville District Administrative Team

Attn: Superintendent - Tyler Walker
421 E. Hwy 124
Hallsville, MO 65255

Dr. Walker,

Please find enclosed the monthly report for the New All Purpose Field & Parking Lot, Primary School Classroom Addition, and Secure Entry Doors projects. Included in this report, you will find an update on the construction progress for the All Purpose Field & Parking Lot project, as well as the mobilization plan for the Primary School Classroom Addition and Secure Entry Doors projects.

For the All Purpose Field & Parking Lot project, the earthwork subcontractor has cut in and graded the drive lane, and began grading at the new All Purpose Field. The concrete subcontractor began laying fabric and rock down on the drive lane in preparation for the asphalt paving.

GMP Amendment 03 for the Primary School Classroom Addition and Secure Entry Doors was reviewed and approved in a special session board meeting in April. Subcontracts for the 04A Masonry, 05A Steel, 06A General Works, 07H Roofing & Sheet Metal, 08H Glass & Glazing, 09A Drywall & Acoustical Ceilings, 09L Painting, 21A Fire Protection, 23A Mechanical, and 26A Electrical scopes of work have been issued. We plan to start construction on the Classroom Addition towards the end of May, and we plan to begin work at the Secure Entry Doors in early June.

Should you have any questions or concerns regarding this report, please let me know.

Sincerely,



Moriah Ellis | Assistant Project Manager

[St. Louis](#) | [Edwardsville](#)

cell number: 314.978.8012

II. Design & Engineering Update:

Design & Engineering Narrative:

All Purpose Field & Parking Lot

Klinger & Associates issued Supplemental Instruction 004 on April 20, 2026. These revised drawings included moving one of the bullpens back to the original location on the first base line. The grading plan to the North of the bullpens had to be revised accordingly, in order to avoid the gas lines.

The Klingner team is working on submittal reviews and RFI responses as needed for this project.

Primary School Classroom Addition and Secure Entry Doors

Klinger & Associates issued Supplemental Instruction 001 for the Early Bid Package Drawings on May 12, 2026. These revised drawings included adding dimensions and the architectural layout to the structural plan drawing for clarity, updating the column schedule, anchor bolt schedule, and footing schedules, and adding clarification notes on a detail for the footings and column pad footings.

The Klingner team is working on submittal reviews and RFI responses as needed for this project as well.

III. Contracting Update:

Contract Changes:

COR 009 (OCO-004) - Bid Package #3 Primary School Addition & Secure Entry Doors

- This has been pushed through to Dr. Walker as OCO-004 for official approval, as it was already “approved” in GMP Amendment #3

COR 010 - Remove & Reinstall Storm Pipe to Lower Fiber Line

COR 011 - SI 003 Shift Grading West of Site to Avoid Gas Lines

COR 012 - Schnieders Overtime on 05/02/26

No additional contract changes for the month of May.

See Change Order Requests in review attached.



S. M. Wilson & Co.
 2185 Hampton Ave., St. Louis, MO 63139
 222 1st Ave., Suite A, Edwardsville, IL 62025

CHANGE ORDER REQUEST
No. 10

TO: HALLSVILLE R-IV SCHOOL DISTRICT
 421 E. Hwy 124
 Hallsville MO 65255

JOB #: 0125005.00

ATTN: Tyler Walker

JOB NAME: Hallsville 2025 Bond Issue

RE: Remove & Reinstall Storm Pipe to Lower Fiber Line

DATE: May 06, 2026

While Bluebird was on site lowering the fiber line that crosses the proposed drive lane, we realized the fiber line conflicted with the grades of the drive lane and swales on either side, so the fiber line would need to go below the storm pipe between Storm Structures 12 & 13. The storm pipe had to be removed and reinstalled, so that the fiber line could drop below. The Schnieders earthwork crew submitted a T&M ticket for this work.

Description	Net Amount
Schnieders	
T&M ticket to remove and reinstall storm pipe between Structures 12 & 13, to drop fiber line	4,505.16
Subtotal:	\$4,505.16
	SDI: \$56.31
	SDI: \$0.00
Performance & Payment Bond:	\$48.96
General Liability:	\$56.29
	FEE: \$228.07
Total Cost:	\$4,894.79

- NOTES:
1. The approval of this Change Order Request is important to the progress of this project. Your approval is required as soon as possible. Upon execution of this Change Order Request, a Change Order will be processed and forwarded to you for signature.
 2. This work is on hold pending authorization unless previously authorized.
 3. Extension of time necessary for this change is 0 calendar days.

This form will serve as our written authorization to proceed with the above work pending an official change order to our contract showing the revised contract amount.

HALLSVILLE R-IV SCHOOL DISTRICT

KLINGNER & ASSOCIATES, P.C.

S. M. WILSON & CO.

Tyler Walker

Matthew Bridges

Moriah Ellis

 Authorized Signature

 Authorized Signature

 Authorized Signature

 Date

05/07/2026

 Date

05/06/2026

 Date

JS Excavating, Inc.

Operator/Laborer								
Date	Apr. 23-24 - 23		Mon	Tues	Wed	Thur	Fri	Sat
Customer	S.M. Wilson							
Job No. & Location	Hallsville					TIME	Hours	
Machine Time & Machine #	Operator - Excavator					to	8	
Machine Time & Machine #	Laborer -					to	8	
Machine Time & Machine #	Removed Storm Drain					to		
Moving Time	+ Reinstall For Lowering							
Maintenance Time	Fiber Line							
Lunch						—		
Labor (Description)						to		
Labor (Description)						to		
Shop Time (Description)						to		
Total Man Hours for Day	1 Load 1" Clean (20TN)					to		
Material Used						16		
Hired Trucks								
Name	Hours	Dirt Loads	Rock Crushed	Truck Size	Rate	Charge To		
<i>[Signature]</i>								

TIME SHEETS TO BE FILLED OUT ON DAILY BASIS





S. M. Wilson & Co.
 2185 Hampton Ave., St. Louis, MO 63139
 222 1st Ave., Suite A, Edwardsville, IL 62025

CHANGE ORDER REQUEST
No. 11

TO: HALLSVILLE R-IV SCHOOL DISTRICT
 421 E. Hwy 124
 Hallsville MO 65255

JOB #: 0125005.00

ATTN: Tyler Walker

JOB NAME: Hallsville 2025 Bond Issue

RE: SI 003 - Shift Grading West of Site to Avoid Gas Lines

DATE: May 06, 2026

Per the SI 003 revised drawings from April 7, the storm pipe between structures 5 & 6 was lengthened by 15 ft, and the grading on the West side of the site was shifted so soil can be stockpiled to West of storm detention basin. Both changes were made in order to avoid the gas lines.

Description	Net Amount
Schnieders	
Provide all tools, equipment, materail, and labor to furnish and install an additional 15 feet of reinforced concrete pipe between Storm Structures 5 & 6.	1,873.63
	Subtotal: \$1,873.63
	SDI: \$23.42
	SDI: \$0.00
	Performance & Payment Bond: \$20.36
	General Liability: \$23.41
	FEE: \$94.85
	Total Cost: \$2,035.67

- NOTES:
1. The approval of this Change Order Request is important to the progress of this project. Your approval is required as soon as possible. Upon execution of this Change Order Request, a Change Order will be processed and forwarded to you for signature.
 2. This work is on hold pending authorization unless previously authorized.
 3. Extension of time necessary for this change is 0 calendar days.

This form will serve as our written authorization to proceed with the above work pending an official change order to our contract showing the revised contract amount.

HALLSVILLE R-IV SCHOOL
 DISTRICT

KLINGNER & ASSOCIATES, P.C.

S. M. WILSON & CO.

Tyler Walker

Matthew Bridges

Moriah Ellis

 Authorized Signature

 Authorized Signature

 Authorized Signature

 Date

05/07/2026

 Date

05/06/2026

 Date



Quote Number: **Q10042227-0**
 Created On: 12/11/2025
 Quote Expires On: 1/10/2026

Project: Hallsville High School

Account: Jeff Schnieders Construction Company

Project Address: 451 E Highway 124
 Hallsville, Missouri 65255

Account Number: 2142
 Contact: HANNAH HOXWORTH

Estimated Start Date: 3/2/2026

E-mail: assistant@jscci.com

Project End Date: 4/30/2026

Phone: 573-636-7335

Customer Service: 573-445-8393
 Sales Office Address: 2510 N STADIUM BLVD
 COLUMBIA, MO US 65202

MATERIAL PRICING

Item Code	Description	Quantity	Price/Unit (FOB)	Freight	Delivered Price/Unit
→ 205	1" CLEAN Stone: BQ - West Quarry	1 Ton	\$21.45	\$6.15/Ton	\$27.60
306	COMMERCIAL 1" BASE Stone: BQ - West Quarry	1 Ton	\$14.85	\$6.15/Ton	\$21.00
308	MODOT TYPE 5 BASE Stone: BQ - West Quarry	1 Ton	\$15.95	\$6.15/Ton	\$22.10
302	2" BASE Stone: BQ - West Quarry	1 Ton	\$15.15	\$6.15/Ton	\$21.30
215	2" CLEAN Stone: BQ - West Quarry	1 Ton	\$20.65	\$6.15/Ton	\$26.80
800	FINES Stone: BQ - West Quarry	1 Ton	\$5.25	\$6.15/Ton	\$11.40
235	Graded Rip-Rap 6" X 12" Stone: BQ - West Quarry	1 Ton	\$23.65	\$6.65/Ton	\$30.30

SUNDRIES AND SURCHARGES

Item	Comments	Price	Unit
Fuel Surcharge		0.00%	PCT
Energy Surcharge		0.00%	PCT

Respectfully,

Customer Acceptance

Boone Quarries

Signed by:

Sales Rep: Joshua Tiffany

Date:

Phone: 573-228-7076

Email: jtiffany@summit-materials.com

Taxable Tax Exempt (Attach Certificate)



ST LOUIS PIPE

12950 GRAVOIS ROAD
ST LOUIS, MO 53127

REVISED
Quotation

www.countymaterials.com

Date: 12/15/2025	Bid Date: 12/16/2025	Time: 12:00 AM	Project: 110-1379-25	Revision: 2
Bid To: Schnieders Excavating Company	Project Name: Hallsville All Purpose Field and Parking			
Buyer: Hannah Hoxworth	Project Address: 110-1379-25			
Phone: 573-636-7335	City/State/County: Hallsville, MO, BOONE			
Email: hannah@jscci.com	Memo:			
Quoted By: Joel Gardner				Cell: (314)964-9029
Email: joel.gardner@countymaterials.com				

Description	UOM	Qty	Unit Price	Extension
ROUND PIPE				
18" STORM RCP CL3	LF	168.00	\$25.30	\$4,250.40
PAIL OF LUBE - PURE LUBE 400	EA	1.00	\$85.00	\$85.00
*RCP meets ASTM C-76 and C-443 specifications				
*All RCP quoted is for storm sewer only				
12" STORM RCP GASKETS	LF	15.00	\$4.00	\$60.00
Net Price				\$4,395.40
ROUND END SECTIONS				
12" FES (1-M)	EA	1.00	\$641.00	\$641.00
18" FES (2-F,2-M)	EA	4.00	\$962.00	\$3,848.00
LTL DELIVERY CHARGE	EA	1.00	\$425.00	\$425.00
Net Price				\$4,914.00
Total Net Price				\$9,309.40

Subject to all applicable taxes. Please provide the sales tax exempt certificate with your acceptance of this quotation, when applicable. Product will not be shipped if tax exempt certificate is not received for a tax exempt project.

Quantities indicated are estimates only. Buyer is responsible for verification of quoted quantities, sizes, classes of material and conformance with applicable specification(s). Unless specifically noted on quotation, pricing excludes joint testing, admixtures, coatings, tie bolts, gaskets, and televised inspection.

Freight: FOB Jobsite for full loads; truck near as possible to jobsite under own power. Buyer to unload.

A minimum drop charge may apply on less than full truckload quantities.

All returns are subject to a 30% restocking charge. Return Freight charges will also be applied. ALL DESIGN/SPECIALTY ITEMS ARE NON RETURNABLE, NON REFUNDABLE, & REQUIRE A SIGNED ORDER OR PURCHASE ORDER.

In instances where pipe class is not designed or shown on the project plans, as is customary standard of care in the industry, the pipe class quoted is the Seller's interpretation of DOT standards. Approval of the necessary pipe class is required on the the shop drawing.

By acceptance, the buyer agrees they will purchase ALL items enumerated herein from CMC in such quantities as are required to complete this project.

This bid also is contingent upon successful negotiations of the terms and conditions of the contract for this project, between County Materials Corporation and the General Contractor / Contractor / Subcontractor / Buyer.

Payment Terms: This bid is subject to establishing an account or acceptable credit with the Company. All invoices are due and payable by the end of the month following the month of purchase. Invoices not paid when due shall accrue interest at the rate of 1-1/2% per month (18% per annum).

Contract: This proposal when signed by Seller and Buyer constitutes a binding contract and is made for acceptance within thirty (30) days from date hereof. No other contract will be signed unless this quotation and its terms and conditions are made a part thereof. If this is not a quotation, If Buyer fails to sign, the terms and conditions of this document shall become binding upon Seller's delivery or commencement of delivery. Any additional terms and conditions proposed by Buyer, whether written or verbal, are rejected and shall be of no force or effect unless expressly consented to in writing by the Seller.

18" RCP 25.30 + 16.35 = \$ 4165 / LF

April 7, 2026

SUPPLEMENTAL INSTRUCTION 3 (SI 3)

For work titled: New All Purpose Field and Parking Lot

TO GENERAL CONTRACTOR

GENERAL NOTES

This Supplemental Instructions is issued for the purpose of clarifying the design intent of the Construction Documents.

The Work shall be carried out in accordance with the following supplemental instructions issued in accordance with the Contract Documents without change in Contract Sum or Contract Time. Proceeding with the Work in accordance with these instructions indicates your acknowledgment that there will be no change in the Contract Sum or Contract Time. **If there is to be a change to contract cost or time, the contractor is responsible for providing this information in writing for approval before they begin work. A break down of cost for material and labor for both the general contractor and subcontractors is required for all change order requests.**

This Supplemental Instructions consists of One (1) – 8 1/2" x 11" page including this cover sheet and four (4) - 30" x 42" sheets.

DESCRIPTION

1	Sheet C201	Revised grading to move soil stockpile to south side of detention basin.
2	Sheet C202	Revised grading to move soil stockpile to south side of detention basin.
3	Sheet C301	Revised storm sewer due to grading revision to move soil stockpile south of detention basin.
4	Sheet C302	Revised storm sewer due to grading revision to move soil stockpile south of detention basin.

ATTACHMENTS

Sheets C201, C202, C301, and C302 - (30x42)

END OF SUPPLEMENTAL INSTRUCTIONS 3

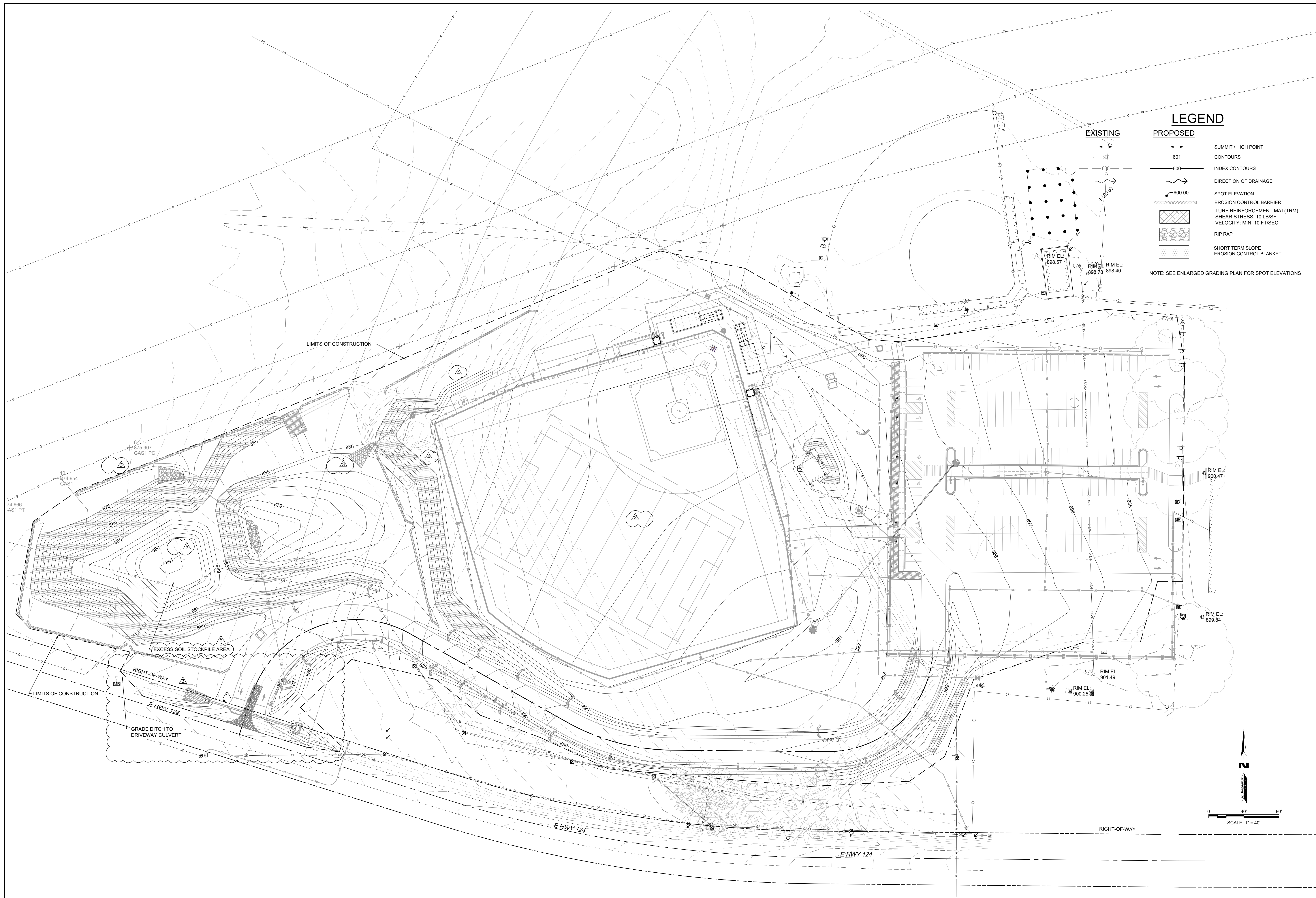

LEGEND

EXISTING	PROPOSED	
—	—	SUMMIT / HIGH POINT
—	—	CONTOURS
—	—	INDEX CONTOURS
—	—	DIRECTION OF DRAINAGE
—	—	SPOT ELEVATION
—	—	EROSION CONTROL BARRIER
—	—	TURF REINFORCEMENT MAT (TRM)
—	—	SHEAR STRESS: 10 LBS/PSF
—	—	VELOCITY: MIN. 10 FT/SEC
—	—	RIP RAP
—	—	SHORT TERM SLOPE
—	—	EROSION CONTROL BLANKET

NOTE: SEE ENLARGED GRADING PLAN FOR SPOT ELEVATIONS

KLINGNER & ASSOCIATES, P.C.
 Engineers • Architects • Surveyors
 Columbia, Missouri
 www.klingner.com
 3622 Englewood Ave., Ste 117
 Davenport, IA, Carbondale, IL

This document shall not be used for any purpose or project for which it is not intended. Klingner & Associates, P.C. and their Division shall be indemnified by the client and not liable for any claims, damages, liabilities, losses and expenses, including attorneys fees and costs of suit, in and out of court, arising from or due to the use of this document, in whole or in part, in any manner, in any jurisdiction.

NO.	DESCRIPTION	DATE	BY
1	MOVE ENTRANCE PIPE & REVISE GRADES	1/21/25	DCD
2	RIP RAP	2/24/25	DCD
3	REVISE GRADES TO MATCH FROM NATURAL GAS MAIN	3/26/25	DCD
4	MOVE SOIL STOCKPILE TO SOUTH SIDE OF DETENTION	3/17/25	DCD

Klingner & Associates, P.C.
 Missouri State Certificate of Authority
 No. E-000896
 ISSUED FOR: 11/14/2025

BIDDING DOCUMENTS

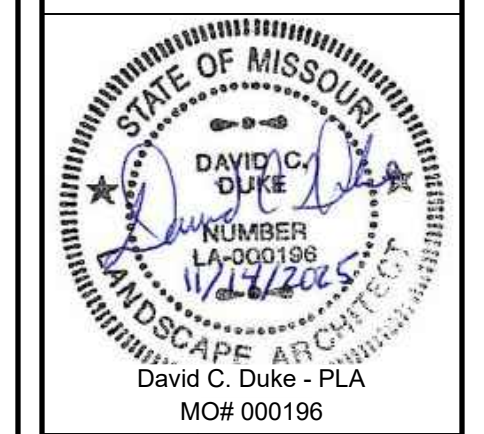

David C. Duke - FLA
 MO# 000196

NEW ALL PURPOSE FIELD AND PARKING LOT
HALLSVILLE R-IV SCHOOL DISTRICT
411 E. HIGHWAY 124
HALLSVILLE, MO 65255

Non-Reduced Sheet Size: 30" x 42"
 All sheet plans have been prepared using standard scales. Reduced size plans may not conform to standard scales.

DESIGNED	DCD	DCD/DDR
DRAWN	FIELD	FIELD BOOK
	MAN/FTGH	H25/35
CHECKED	CSW	CHECK DATE
		11/11/2025

OVERALL GRADING & EROSION CONTROL PLAN

PROJECT NO: 24-5017
 DRAWING ISSUED DATE: 11/14/2025
 SHEET
C201

BENCHMARKS:
 2. SOUTHEAST CORNER CONCRETE PAD FOR ELECTRIC TRANSFORMER SOUTHEAST CORNER BASEBALL FIELD - ELEV 899.64 (FROM TOPOGRAPHIC SURVEY BY ALLSTATE CONSULTANTS, P.C. JOB #04345.01) USED FOR KLINGNER PROJECT NO. 21-5052.
 6. CHISELED "□" NORTHWEST CORNER CONCRETE PAD SOUTH OF DISCUS PAD - ELEV 898.22

This document shall not be used for any purpose or project for which it is not intended. Klingner & Associates, P.C. and their Division shall be indemnified by the client and not liable for any claims, damages, liabilities, losses and expenses, including attorneys fees and costs, arising out of any use or reuse of this document, in part or in whole, as prohibited.

NO.	DESCRIPTION	DATE	BY
1	MOVE ENTRANCE PIPE & ADJUST GRADES	1/21/20	DCD
2	RFI #002	2/24/20	DCD
3	RFI #004	2/24/20	DCD
4	REVISE GRADES TO NATURAL GAS MAIN	3/9/20	DCD
5	MOVE SOIL STRUCTURE TO SOUTH SIDE OF DETENTION	3/17/20	DCD

Klingner & Associates, P.C.
 Missouri State Certificate of Authority
 No. E-000896
 ISSUED FOR: 11/14/2025

BIDDING DOCUMENTS

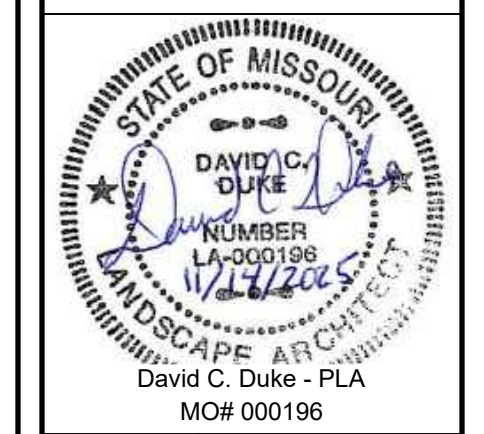

David C. Duke - FLA
 MO# 000196

NEW ALL PURPOSE FIELD AND PARKING LOT
HALLSVILLE R-IV SCHOOL DISTRICT
411 E. HIGHWAY 124
HALLSVILLE, MO 65255

Non-Reduced Sheet Size: 30" x 42"
 All sheet plans have been prepared using standard scales. Reduced size plans may not conform to standard scales.

DESIGNED	DCD/DDR
FIELD	FIELD BOOK
MAN/FGH	H25/05
CHECKED	CHECK DATE
CSW	11/11/2025

SHEET TITLE

ENLARGED GRADING & EROSION CONTROL PLAN - WEST

PROJECT NO: 24-5017
 DRAWING ISSUED DATE: 11/14/2025
 SHEET
C202

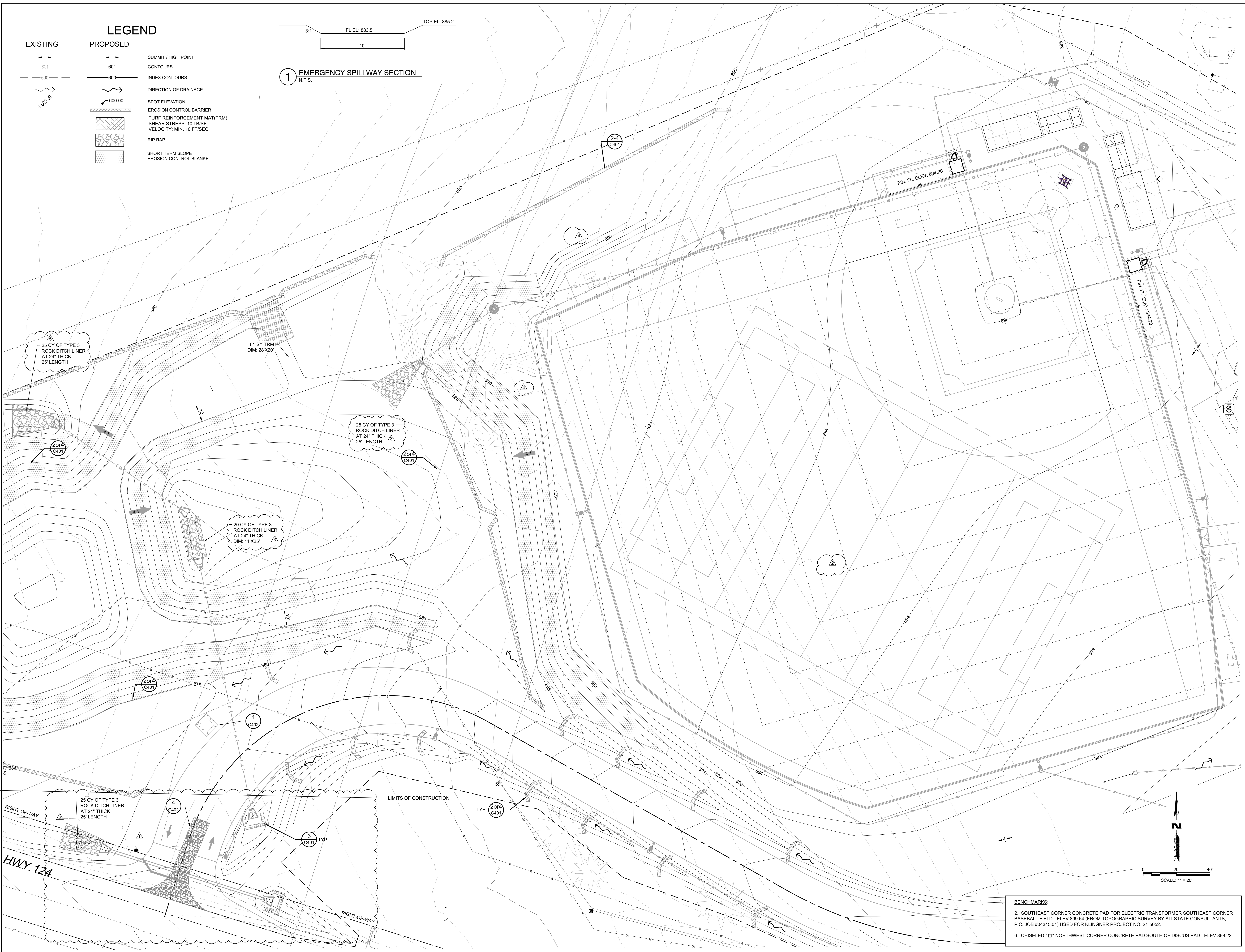

LEGEND

- | | | |
|-----------------|-----------------|------------------------------|
| EXISTING | PROPOSED | SUMMIT / HIGH POINT |
| --- 601 --- | --- 601 --- | CONTOURS |
| --- 600 --- | --- 600 --- | INDEX CONTOURS |
| ~> | ~> | DIRECTION OF DRAINAGE |
| +800.00 | ~> | SPOT ELEVATION |
| | --- 600.00 --- | EROSION CONTROL BARRIER |
| | [Pattern] | TURF REINFORCEMENT MAT (TRM) |
| | [Pattern] | SHEAR STRESS: 10 LB/FSF |
| | [Pattern] | VELOCITY: MIN. 10 FT/SEC |
| | [Pattern] | RIP RAP |
| | [Pattern] | SHORT TERM SLOPE |
| | [Pattern] | EROSION CONTROL BLANKET |



BENCHMARKS:
 2. SOUTHEAST CORNER CONCRETE PAD FOR ELECTRIC TRANSFORMER SOUTHEAST CORNER BASEBALL FIELD - ELEV 899.64 (FROM TOPOGRAPHIC SURVEY BY ALLSTATE CONSULTANTS, P.C. JOB #04345.01) USED FOR KLINGNER PROJECT NO. 21-5052.
 6. CHISELED "□" NORTHWEST CORNER CONCRETE PAD SOUTH OF DISCUS PAD - ELEV 898.22

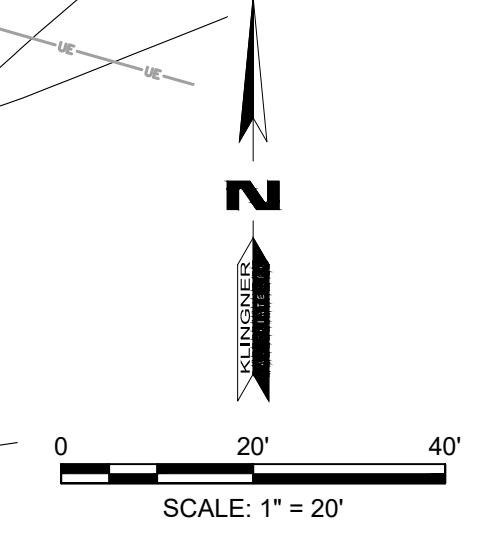

DRAINAGE STRUCTURE SCHEDULE		
STRUCT. #	DESCRIPTION	GRATE TYPE
2	48" Ø MANHOLE (DETAIL 3/C502)	R-1713 GRATE W/FRAME & SOLID LID
3	48" Ø MANHOLE (DETAIL 3/C502)	R-1713 GRATE W/FRAME & SOLID LID
4	48" Ø MANHOLE (DETAIL 6/C502)	NEENAH R-2533 FRAME AND TYPE A GRATE

DRAINAGE STRUCTURE FES SCHEDULE		
FES #	DESCRIPTION	GRATE TYPE
1	15" REINFORCED CONCRETE PIPE F.E.S.	N/A
5	18" REINFORCED CONCRETE PIPE F.E.S.	N/A
6	18" REINFORCED CONCRETE PIPE F.E.S.	N/A
7	12" REINFORCED CONCRETE PIPE F.E.S.	N/A
8	12" REINFORCED CONCRETE PIPE F.E.S.	N/A
12	18" REINFORCED CONCRETE PIPE F.E.S.	N/A
13	18" REINFORCED CONCRETE PIPE F.E.S.	N/A

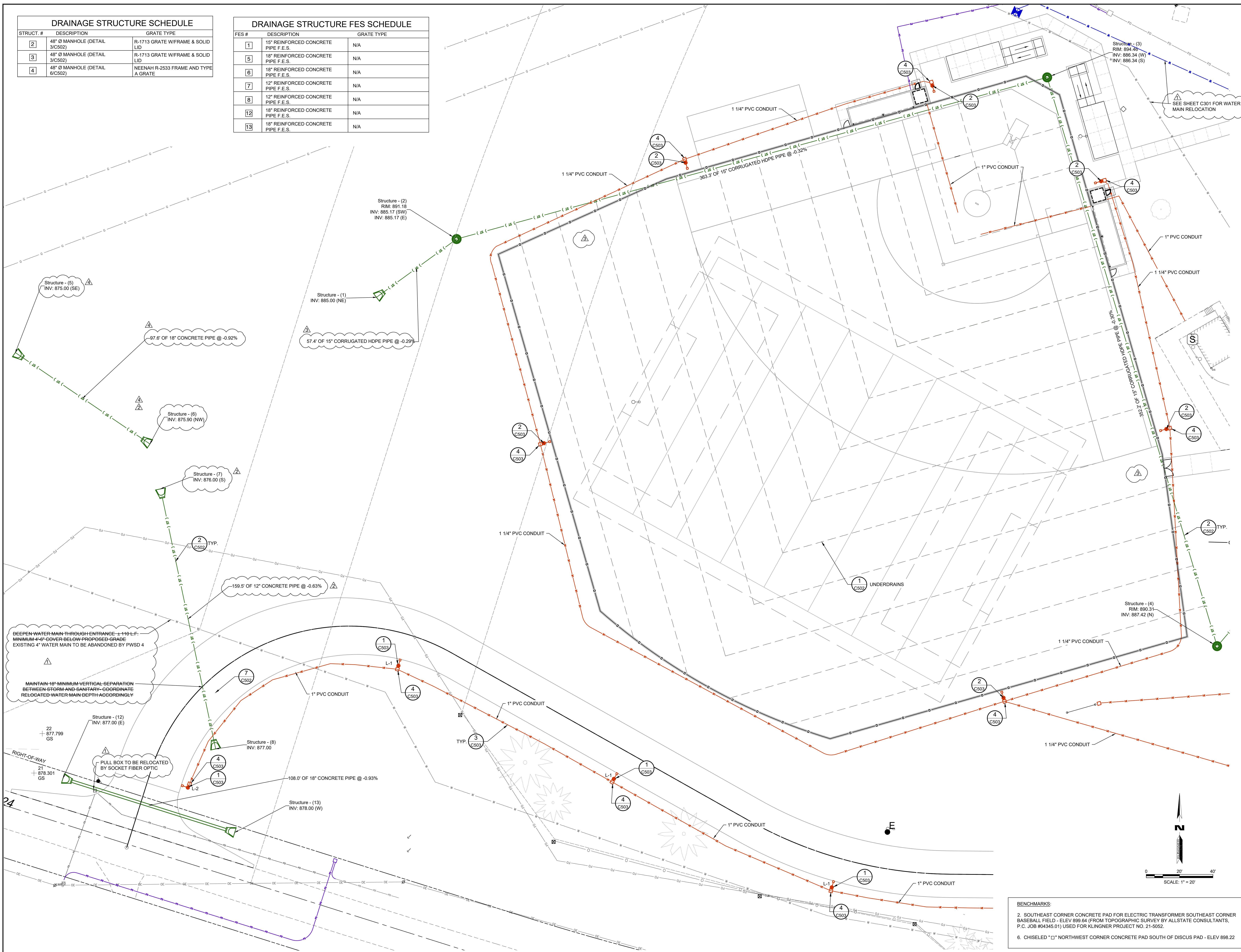

KLINGNER & ASSOCIATES, P.C.
 Engineers • Architects • Surveyors
 Columbia, Missouri
 3622 Embury Ave., Ste 117
 Burlingame, IA 50301
 573.355.9988

This document shall not be used for any purpose or project for which it is not intended. Klingner & Associates, P.C. and their Client shall be indemnified by the client and hold harmless from all claims, damages, liabilities, losses and expenses, including attorneys fees and costs, arising out of such misuse or reuse of this document, in part or in whole, as prohibited.

REVISION HISTORY		
NO.	DESCRIPTION	DATE
1	ISSUE FOR BIDDING	11/14/2025
2	REVISE GRADES & PIPE	10/10/25
3	REV. 2025	09/08/25
4	MOVE SOL. STOCKPILE TO SOUTH SIDE OF LOT	3/17/25

Klingner & Associates, P.C.
 Missouri State Certificate of Authority
 No. E-000886
 ISSUED FOR: 11742025

BIDDING DOCUMENTS

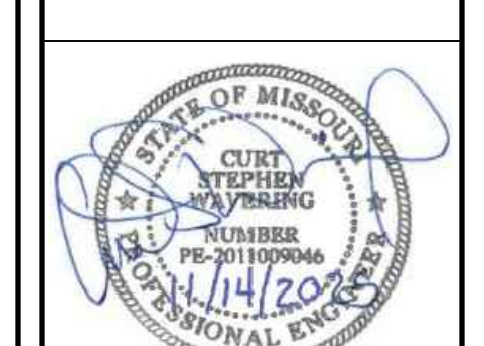

Curt S. Wavering - Engineer
 MO# 2011009046

NEW ALL PURPOSE FIELD AND PARKING LOT
HALLSVILLE R-IV SCHOOL DISTRICT
411 E. HIGHWAY 124
HALLSVILLE, MO 65255

Non-Reduced Sheet Size: 30" x 42"
 Full sized plans have been prepared using standard scales. Reduced size plans may not conform to standard scales.

DESIGNED	DCD/DDR
FIELD	FIELD BOOK
MAN/FGH	H2505
CHECKED	CHECK DATE
CSW	11/11/2025

SHEET TITLE
ENLARGED SITE UTILITY PLAN - WEST

PROJECT NO.
 24-5017

DRAWING ISSUED DATE:
 11/14/2025

SHEET
C302

BENCHMARKS:
 2. SOUTHEAST CORNER CONCRETE PAD FOR ELECTRIC TRANSFORMER SOUTHEAST CORNER BASEBALL FIELD - ELEV 899.64 (FROM TOPOGRAPHIC SURVEY BY ALLSTATE CONSULTANTS, P.C. JOB #04345.01) USED FOR KLINGNER PROJECT NO. 21-5052.
 6. CHISELED " " NORTHWEST CORNER CONCRETE PAD SOUTH OF DISCUS PAD - ELEV 898.22

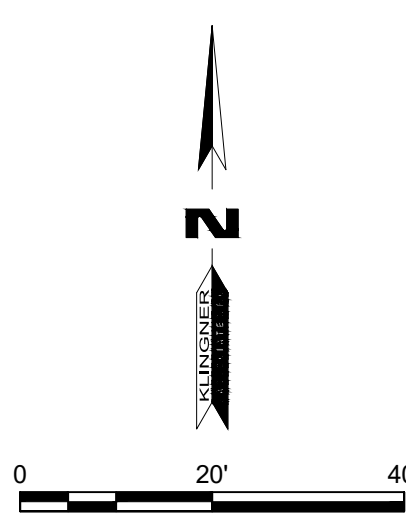



S. M. Wilson & Co.
 2185 Hampton Ave., St. Louis, MO 63139
 222 1st Ave., Suite A, Edwardsville, IL 62025

**CHANGE ORDER REQUEST
 No. 12**

TO: HALLSVILLE R-IV SCHOOL DISTRICT
 421 E. Hwy 124
 Hallsville MO 65255

JOB #: 0125005.00

ATTN: Tyler Walker

JOB NAME: Hallsville 2025 Bond Issue

RE: Schnieders Overtime on 05/02/26

DATE: May 06, 2026

An operator with Schnieders worked 8.5 hours on Saturday, May 2nd, in order to continue to grade the new turf field, while the site was dry.

Description	Net Amount
Schnieders	
Premium time for operator to work OT on 05/02/26	467.78
	Subtotal: \$467.78
	SDI: \$5.85
	SDI: \$0.00
	Performance & Payment Bond: \$5.08
	General Liability: \$5.85
	FEE: \$23.68
	Total Cost: \$508.24

- NOTES: 1. The approval of this Change Order Request is important to the progress of this project. Your approval is required as soon as possible. Upon execution of this Change Order Request, a Change Order will be processed and forwarded to you for signature.
 2. This work is on hold pending authorization unless previously authorized.
 3. Extension of time necessary for this change is 0 calendar days.

This form will serve as our written authorization to proceed with the above work pending an official change order to our contract showing the revised contract amount.

HALLSVILLE R-IV SCHOOL DISTRICT

KLINGNER & ASSOCIATES, P.C.

S. M. WILSON & CO.

Tyler Walker

Matthew Bridges

Moriah Ellis

 Authorized Signature

 Authorized Signature

 Authorized Signature

 Date

05/07/2026

 Date

05/06/2026

 Date

Schnieders Excavating Co.

Operator/Laborer	Austin							
Date	5-2-26		Mon	Tues	Wed	Thur	Fri	Sat
Customer	Sm Wilson							
Job No. & Location	Hellsville All Purpose field				TIME	Hours		
Machine Time & Machine #					to			
Machine Time & Machine #	Saturday operator OT				to		8.5 hrs	
Machine Time & Machine #	Premium				to			
Moving Time								
Maintenance Time								
Lunch								
Labor (Description)					to			
Labor (Description)					to			
Shop Time (Description)					to			
Total Man Hours for Day					to			
Material Used								
Hired Trucks								
Name	Hours	Dirt Loads	Rock Crushed	Truck Size	Rate	Charge To		

TIME SHEETS TO BE FILLED OUT ON DAILY BASIS



IV. Financial & Budget Update:

Monthly Construction Pay Request:

S. M. Wilson & Co. has submitted the second pay application for the month of April for Owner and Design Team review. Please see attached. Per the contract we will submit monthly pay applications on the 5th day of each month and project the cost through the end of the month.

APPLICATION AND CERTIFICATE FOR PAYMENT

Invoice #: 0125005-02

To HALLSVILLE R-IV SCHOOL DISTRICT Project 0125005.00 Hallsville 2025 Bond Issue
 Owner:

Application No. : 2

Distribution to :

Owner

Architect

Contractor

Period To:

From Contract S. M. Wilson & Co.
 2185 Hampton Ave.
 St. Louis MO 63139

Via KLINGNER & ASSOCIATES, P.C.
 Architect: 616 North 24th Street
 Quincy IL 62301

Project Nos:

Contract For:

Contract 4/18/2025

CONTRACTOR'S APPLICATION FOR PAYMENT

Application is made for payment, as shown below, in connection with the Contract. Continuation Sheet is attached.

1. Original Contract Sum	\$3,969,262.00
2. Net Change By Change Order	\$266,801.78
3. Contract Sum To Date	\$4,236,063.78
4. Total Completed and Stored To Date	\$398,164.99
5. Retainage:	
a. 5.00% of Completed Work	\$19,162.00
b. 5.00% of Stored Material	\$746.24
Total Retainage	\$19,908.24
6. Total Earned Less Retainage	\$378,256.75
7. Less Previous Certificates For Payments	\$255,051.61
8. Current Payment Due	\$123,205.14
9. Balance To Finish, Plus Retainage	\$3,857,807.03

The undersigned Contractor certifies that to the best of the Contractor's knowledge, information, and belief, the work covered by this Application for Payment has been completed in accordance with the Contract Documents. That all amounts have been paid by the Contractor for Work for which previous Certificates for Payment were issued and payments received from the Owner, and that current payment shown herein is now due.

CONTRACTOR: S. M. Wilson & Co.

By: Marcel Ellis Date: 05/05/2025

State of: Missouri County of: Franklin
 Subscribed and sworn to before me this 5th day of May, 2026
 Notary Public: Rebecca Michelle Geiger
 My Commission expires: 7/11/2026

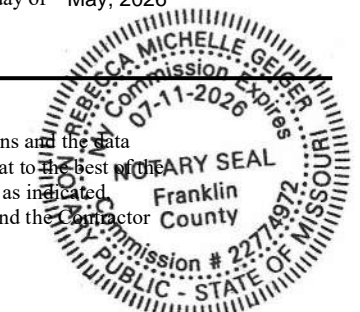

ARCHITECT'S CERTIFICATE FOR PAYMENT

In accordance with the Contract Documents, based on on-site observations and the data comprising the above application, the Architect certifies to the Owner that to the best of the Architect's knowledge, information, and belief, the Work has progressed as indicated, the quality of the Work is in accordance with the Contract Documents, and the Contractor is entitled to payment of the AMOUNT CERTIFIED.

AMOUNT CERTIFIED \$123,205.14

(Attach explanation if amount certified differs from the amount applied. Initial all figures on this Application and on the Continuation Sheet that are changed to conform with the amount certified.)

ARCHITECT:

By: _____ Date: _____

This Certificate is not negotiable. The AMOUNT CERTIFIED is payable only to the Contractor named herein. Issuance, payment, and acceptance of payment are without prejudice to any rights of the Owner or Contractor under this Contract.

CHANGE ORDER SUMMARY	ADDITIONS	DEDUCTIONS
Change Orders approved previously	0.00	0.00
OCO-001	108,375.78	0.00
OCO-002	160,026.00	0.00
OCO-003	0.00	-1,600.00
CURRENT TOTAL	\$268,401.78	\$1,600.00
Net Change by Change Orders		\$266,801.78

CONTINUATION SHEET

Application and Certification for Payment, containing Contractor's signed certification is attached.
 In tabulations below, amounts are stated to the nearest dollar.
 Use Column I on Contracts where variable retainage for line items may apply.

Application No. : 2
 Application Date : 05/05/26
 To:
 Architect's Project No.:

Invoice # : 0125005-02 Contract : 0125005.00 Hallsville 2025 Bond Issue

A Item No.	B Description of Work	C Scheduled Value	D E Work Completed		F Materials Presently Stored (Not in D or E)	G Total Completed and Stored to Date (D+E+F)	H % (G / C)	I Balance to Finish (C-G)	Retainage
			From Previous Application (D+E)	This Period in Place					
00	Contracting Requirements								
FEE	FEE	118,651.00	7,629.01	3,524.18	0.00	11,153.19	9.40%	107,497.81	557.66
006110	Performance & Payment Bond	41,249.00	26,416.00	0.00	0.00	26,416.00	64.04%	14,833.00	1,320.80
007310	General Liability Insurance	47,436.00	45,596.00	0.00	0.00	45,596.00	96.12%	1,840.00	2,279.80
007325	Subcontractor Default Insurance (SDI)	43,028.00	41,159.00	0.00	0.00	41,159.00	95.66%	1,869.00	2,057.95
010110	General Conditions	401,300.00	25,650.24	32,925.67	0.00	58,575.91	14.60%	342,724.09	2,928.79
010810	General Requirements	140,729.00	849.01	98.79	0.00	947.80	0.67%	139,781.20	47.39
011240	Preconstruction Services	10,000.00	10,000.00	0.00	0.00	10,000.00	100.00%	0.00	500.00
011510	Building Permit Fee	12,375.00	0.00	4,184.46	0.00	4,184.46	33.81%	8,190.54	209.22
011520	Fire Permit Fee	2,063.00	0.00	0.00	0.00	0.00	0.00%	2,063.00	0.00
022100	Surveys	13,000.00	2,000.00	0.00	0.00	2,000.00	15.38%	11,000.00	100.00
	Contracting Requirements Total:	829,831.00	159,299.26	40,733.10	0.00	200,032.36	24.11%	629,798.64	10,001.61
01	Bid Package #1								
030000	Concrete	288,000.00	0.00	0.00	0.00	0.00	0.00%	288,000.00	0.00
040000	Masonry	134,500.00	0.00	0.00	0.00	0.00	0.00%	134,500.00	0.00
061000	Rough Carpentry	58,700.00	0.00	0.00	0.00	0.00	0.00%	58,700.00	0.00
116600	Athletic Equipment	120,700.00	0.00	0.00	0.00	0.00	0.00%	120,700.00	0.00
126600	Bleachers	62,372.00	0.00	0.00	0.00	0.00	0.00%	62,372.00	0.00
260000	Electrical	345,665.39	3,100.00	0.00	14,924.83	18,024.83	5.21%	327,640.56	901.24
310000	Earthwork	519,978.52	98,876.95	81,230.85	0.00	180,107.80	34.64%	339,870.72	9,005.39
321216	Asphalt Paving	495,434.00	0.00	0.00	0.00	0.00	0.00%	495,434.00	0.00
321800	Athletic Surfaces	1,135,769.87	0.00	0.00	0.00	0.00	0.00%	1,135,769.87	0.00
323100	Fences and Gates	115,237.00	0.00	0.00	0.00	0.00	0.00%	115,237.00	0.00
	Bid Package #1 Total:	3,276,356.78	101,976.95	81,230.85	14,924.83	198,132.63	6.05%	3,078,224.15	9,906.63
02	Bid Package #2								
030000-01	Concrete	70,500.00	0.00	0.00	0.00	0.00	0.00%	70,500.00	0.00
220000-01	Plumbing	31,876.00	0.00	0.00	0.00	0.00	0.00%	31,876.00	0.00
310000-01	Earthwork	27,500.00	0.00	0.00	0.00	0.00	0.00%	27,500.00	0.00
	Bid Package #2 Total:	129,876.00	0.00	0.00	0.00	0.00	0.00%	129,876.00	0.00

Grand Totals

4,236,063.78

261,276.21

121,963.95

14,924.83

398,164.99

9.40%

3,837,898.79

19,908.24

**PARTIAL
WAIVER OF LIEN**

STATE OF: MISSOURI

COUNTY OF: ST. LOUIS

The undersigned has been employed by **Hallsville R-IV School District** to furnish labor and material for the project known as **Hallsville School District Locker Room & Stadium Improvements Upgrade, 421 MO-124 E, Hallsville, MO 65255** in the County of Boone, State of Missouri. Now therefore, know ye, that We the undersigned for and in consideration of the sum of **ONE HUNDRED TWENTY THREE THOUSAND TWO HUNDRED FIVE AND 14/100 (\$123,205.14)** and other good and valuable considerations, considered due and payable, do hereby waive and release any and all lien, or claim or right of lien on said above-described building and premises under the Statutes of the State of Missouri relating to Mechanics' Liens on account of labor of materials, or both, furnished by the undersigned to aforesaid purchaser for said building and premises. This waiver is considered valid only to the extent of payments received.

Given under my hand and seal this 5th day of May, 2026.

S. M. Wilson & Co.

Kelly Santacruz

Kelly Santacruz Sr. Project Accountant

Rebecca Michelle Geiger

Rebecca Michelle Geiger-Notary Public

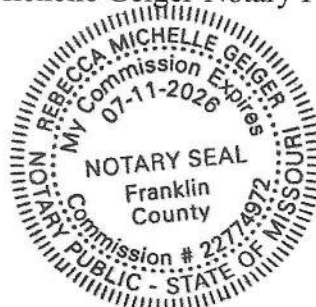

APPLICATION FOR PAYMENT

To: S. M. Wilson & Co.
2185 Hampton Ave
Saint Louis, MO 63139

From: Meyer Electric Co. Inc.
3513 N. Ten Mile Drive
Jefferson City, MO 65109

Contract For: 0125005.00008 - Electrical

Project: Hallsville 2025 Bond Issue

Application No.: 2
Period To: 04/30/26
Application Date: 04/20/26
Project No.: 0125005.00
Contract Date: 03/30/26
Commitment: 0125005.00008

1. ORIGINAL CONTRACT AMOUNT	<u>\$349,123.00</u>
2. NET CHANGE BY CHANGE ORDERS	<u>(\$3,457.61)</u>
3. CONTRACT SUM TO DATE	<u>\$345,665.39</u>
4. TOTAL COMPLETED AND STORED TO DATE	<u>\$18,024.83</u>
(Column G)	
5. RETAINAGE	
5.00% of Completed Work	<u>\$514.96</u>
(Columns D + E)	
5.00% of Stored Materials	<u>\$386.28</u>
(Columns F)	
Total Retainage	<u>\$901.24</u>
(Line 5a + Line 5b OR Sum of Column I)	
6. TOTAL EARNED LESS RETAINAGE	<u>\$17,123.59</u>
(Line 4 less Line 5 Total)	
7. LESS PRIOR CERTIFICATES FOR PAYMENT	<u>\$9,784.21</u>
(Line 6 from prior Certificate)	
8. CURRENT PAYMENT DUE	<u>\$7,339.38</u>
9. BALANCE TO FINISH, INCLUDING RETAINAGE	<u>\$328,541.80</u>
(Line 3 less Line 6)	

The undersigned Contractor certifies that to the best of the Contractor's knowledge, information and belief the Work covered by this Application for Payment has been completed in accordance with the Contract Documents, that all amounts have been paid by the Contractor for Work for which previous Certificates for Payment were issued and payments received from the Owner, and that current payment shown herein is now due.

CONTRACTOR:

By: _____ Date: _____
State Of: _____
County Of: _____
Subscribed and sworn to before me this _____ day of _____
Notary Public: _____
My commission expires: _____

ARCHITECTS CERTIFICATE FOR PAYMENT

In accordance with the Contract Documents, based on the on-site observations and the data compromising this application, the Architect certifies to the owner that to the best of the Architects knowledge, information and belief the Work under the Architect's Contract has progressed as indicated, the quality of Work is in accordance with the Contract Documents, and the Contractor is entitled to payment of the AMOUNT CERTIFIED.

AMOUNT CERTIFIED \$7,339.38

(Attach explanation if amount certified differs from the amount applied for. Initial all figures on the Application for Payment and on the Continuation sheet that are changes to conform to the amount certified.)

ARCHITECT:

By: _____ Date: _____

The Certificate is not negotiable. The AMOUNT CERTIFIED is payable only to the Contractor named herein. Issuance, payment and acceptance of payment are without prejudice to any rights of the Owner or Contractor under this Contract.

CHANGE ORDER SUMMARY	ADDITIONS	DEDUCTIONS
Total changes approved in previous months	\$0.00	\$0.00
Total approved this month	\$0.00	\$3,457.61
TOTALS	\$0.00	\$3,457.61
NET CHANGES by Change Orders		(\$3,457.61)

CONTINUATION SHEET

APPLICATION AND CERTIFICATION FOR PAYMENT,
 containing Contractor's signed Certification is attached.
 In tabulations below, amounts are stated to the nearest dollar.

APPLICATION NO.: 2

APPLICATION DATE: 04/20/26

PERIOD TO: 04/30/26

PROJECT NO.: 0125005.00

Meyer Electric Co. Inc.

A ITEM NUM	B DESCRIPTION OF WORK	C SCHEDULED VALUE	D WORK COMPLETED		F MATERIALS PRESENTLY STORED (NOT IN D OR E)	G		H BALANCE TO FINISH (C - G)	I RETAINAGE (IF VARIABLE RATE)
			FROM PREVIOUS APPLICATION (D+E)	THIS PERIOD		TOTAL COMPLETED AND STORED TO DATE	% (G ÷ C)		
1	Electrical Demo	\$6,200.00	\$3,100.00	-	-	\$3,100.00	50.00%	\$3,100.00	\$155.00
2	Site Lighting	\$36,360.00	-	-	-	-	-	\$36,360.00	-
3	Musco Field Lights	\$70,050.00	-	-	-	-	-	\$70,050.00	-
4	Concrete Pole Base	\$28,000.00	-	-	-	-	-	\$28,000.00	-
5	Trench/Backfill	\$41,200.00	-	-	-	-	-	\$41,200.00	-
6	Branch Circuit Conduit	\$100,885.00	\$6,917.22	-	-	\$6,917.22	6.86%	\$93,967.78	\$345.86
7	Branch Circuit Wiring	\$47,428.00	-	-	-	-	-	\$47,428.00	-
8	PA System	\$17,000.00	-	-	\$7,725.66	\$7,725.66	45.45%	\$9,274.34	\$386.28
9	Trim Out	\$2,000.00	\$281.95	-	-	\$281.95	14.10%	\$1,718.05	\$14.10
2	Electrical (CO #1)	(\$3,457.61)	-	-	-	-	-	(\$3,457.61)	-
PAYMENT TOTALS		\$345,665.39	\$10,299.17	-	\$7,725.66	\$18,024.83	5.21%	\$327,640.56	\$901.24

Audit Trail

Project: Hallsville 2025 Bond Issue (0125005.00)

From: Meyer Electric Co. Inc.

Date	User	Company	Event
05/05/26 13:25 GMT	Sherry Jackson	S. M. Wilson & Co.	Sherry Jackson approved Lien Waiver 'SMW PARTIAL conditional Dated.pdf' for Application For Payment #2 for Meyer Electric Co. Inc.
05/05/26 13:23 GMT	Moriah Ellis	S. M. Wilson & Co.	Moriah Ellis sent Lien Waiver '2nd Tier Lien Waiver Supplier Partial.pdf' for Application For Payment #2 for Meyer Electric Co. Inc. (Tech Electronics Inc)
05/05/26 13:23 GMT	Moriah Ellis	S. M. Wilson & Co.	Moriah Ellis approved Application For Payment #2 for Meyer Electric Co. Inc.
05/05/26 12:58 GMT	Patrick Aylesworth	S. M. Wilson & Co.	Patrick Aylesworth approved Application For Payment #2 for Meyer Electric Co. Inc.
05/05/26 12:45 GMT	Sherry Jackson	S. M. Wilson & Co.	Sherry Jackson approved Application For Payment #2 for Meyer Electric Co. Inc.
05/05/26 11:06 GMT	Travis Kay	Meyer Electric Co. Inc.	Travis Kay submitted Application For Payment #2 for Meyer Electric Co. Inc.
05/05/26 11:02 GMT	Travis Kay	Meyer Electric Co. Inc.	Travis Kay uploaded Lien Waiver 'SMW PARTIAL conditional Dated.pdf' for Application For Payment #2 for Meyer Electric Co. Inc.
04/29/26 13:12 GMT	Moriah Ellis	S. M. Wilson & Co.	Moriah Ellis rejected Application For Payment #2 for Meyer Electric Co. Inc. Comment: For electrical demo: Meyer still needs to demo the field lights at the baseball field, at the end of May when we are able to demo the baseball field. Just disconnected and removed a wire at that existing press box.
04/24/26 14:55 GMT	Sherry Jackson	S. M. Wilson & Co.	Sherry Jackson sent Lien Waiver '2nd Tier Lien Waiver Supplier Partial.pdf' for Application For Payment #2 for Meyer Electric Co. Inc. (Tech Electronics Inc)
04/24/26 14:55 GMT	Sherry Jackson	S. M. Wilson & Co.	Sherry Jackson approved Lien Waiver 'SMW PARTIAL conditional Dated.pdf' for Application For Payment #2 for Meyer Electric Co. Inc.
04/20/26 15:13 GMT	Travis Kay	Meyer Electric Co. Inc.	Travis Kay submitted Application For Payment #2 for Meyer Electric Co. Inc.
04/20/26 15:13 GMT	Travis Kay	Meyer Electric Co. Inc.	Travis Kay uploaded Lien Waiver 'SMW PARTIAL conditional Dated.pdf' for Application For Payment #2 for Meyer Electric Co. Inc.
04/20/26 14:03 GMT	Travis Kay	Meyer Electric Co. Inc.	Marked off checklist item 'All required documents for stored materials (if applicable) billed in this period's pay application have been uploaded.' on Application For Payment #2 for Meyer Electric Co. Inc.
04/20/26 14:03 GMT	Travis Kay	Meyer Electric Co. Inc.	Marked off checklist item 'All of the lower tier subcontractors & suppliers with the required information have been submitted accurately in the Liabilities section.' on Application For Payment #2 for Meyer Electric Co. Inc.
04/20/26 14:03 GMT	Travis Kay	Meyer Electric Co. Inc.	Travis Kay certified information on the liabilities tab.
04/20/26 13:51 GMT	Travis Kay	Meyer Electric Co. Inc.	Travis Kay created Application For Payment #2 for Meyer Electric Co. Inc.

APPROVED



Meyer Electric Company, Inc.

Outstanding Items

04/20/26

- Items below with a "Open" status are extras that we have been told to proceed with and need a change order issued.
- Items below with a "Review" status labeled as "T&M" are extras that we have been told to proceed with but are still outstanding.
- Items below with a "Review" status labeled as "PROPOSAL" are extra work proposals that we are awaiting notice to proceed or a change order.

Order#	ME#	Date	Description	Status	Requested
7180 Hallsville School Baseball & Parking					
NONE				Review	0.00
				Job Totals:	0.00
				Grand Totals:	0.00

↑ THIS SIDE UP ↑
FRAGILE

PJ2601300013
Hallsville R-IV School District
Intermediate School: Pro Sound New
CLCW5-07
3/2/2026 9:24 AM

PACKING LIST ENCLOSED
COLUMBIA MO 65201-0001
NO 852 8-85
3/2/2026 9:24 AM

PJ2601300013
Hallsville R-IV School District
Intermediate School: Pro Sound New
CLCW5-07
3/2/2026 9:24 AM

UP
FRAGILE
HANDLE WITH CARE

PJ2601300013
Hallsville R-IV School District
Intermediate School: Pro Sound New
CLCW5-07
3/2/2026 9:24 AM

6450

PJ2601300013
Hallsville R-IV School District
Intermediate School: Pro Sound New
CLCW5-07
3/2/2026 9:24 AM

CE II + ♻️ ♻️ ♻️ ♻️ ♻️ ♻️
MADE IN CHINA

973
973
973

PJ2601300013
Hallsville R-IV School District
Intermediate School: Pro Sound New
CLCW5-07 14 PCS
2/25/2026 1:18 PM

PJ2601300013
Hallsville R-IV School District
Intermediate School: Pro Sound New
CLCW5-07
3/2/2026 9:24 AM

↑ THIS SIDE UP ↑
FRAGILE

PJ2601300013
Hallsville R-IV School District
Intermediate School: Pro Sound New
CLCW5-07 14 PCS
2/25/2026 1:18 PM

CAUTION
Heavy object.
Team lift required.

GRR-10L

CLCW5-07





Tech Electronics of Columbia, Inc.
 1406 Rangeline St.
 Columbia, MO, 65201-3932
 Phone: 573-875-1516

Invoice

F.I.N.: 43-1306482



Click here to Pay Now

Project No
PJ2601300013

Invoice No	Invoice Date	Customer PO	Customer ID	Site ID
176024	23-Mar-2026	145110	C00020109	C00048728

BILL TO	SHIP TO
Meyer Electric Co., Inc. 3513 North Ten Mile Dr. Jefferson City MO 65109-0000	Meyer Electric Co., Inc. 411 East Hwy. 124 Hallsville MO 65255

Request No	Requestor	Sales Rep	Payment Terms	Exempt Code
		John Morgensen	Due Upon Receipt	TEC REQ'D 3/23/26
Reference	Invoice for Hallsville R-IV School District: Intermediate School: Pro Sound New			

Billing Summary (Does Not Include Applicable Sales Tax)	
Project	Hallsville R-IV School District: Intermediate School: Pro Sound New
Contract Total	\$ 10,669.00
Invoice to Date Total	\$ 7,725.66
Balance Remaining to Invoice	\$ 2,943.34

HS

NOTE:

Sales Total:	7,725.66
Tax Total:	0.00
Total (USD):	7,725.66
Payment/Credit:	0.00
Amount Due:	7,725.66

For ACH/Wire

Routing / ABA# 081006162
 Account# 2714330
 Account Name: Tech Electronics of Columbia, Inc.
 Bank: Enterprise Bank & Trust
 Send Remittance Information To: Accounting@techelectronics.com

For Remit by Mail

Tech Electronics
 PO BOX 66940
 St. Louis, MO
 63166-6940

STATE OF: MO

JOB # 0125005.00

COUNTY OF: Cole

PAY APPLICATION # 2

SUBCONTRACTOR'S CONDITIONAL PARTIAL WAIVER OF LIEN

Leon J. Keller of Meyer Electric Co. Inc. ("Subcontractor")
being first duly sworn, states as follows:

1. I am the President (title and/or position) of Subcontractor, and am familiar with the facts stated herein.
2. Subcontractor has provided to or through S. M. Wilson & Co. ("Contractor") certain labor, supplies, materials, equipment and/or other items for use in the construction of improvements located at Hallsville 2025 Bond Issue , 421 E. Highway 124, Hallsville, MO 65255 (the "Project") owned by HALLSVILLE R-IV SCHOOL DISTRICT ("Owner").
3. Upon receipt by the undersigned of a check payable to the Subcontractor, and when the check has been properly endorsed and has been paid by the bank on which it is drawn Subcontractor hereby waives all rights to a mechanic's lien or to any other claim against the Project, or any improvements thereon, for labor, supplies, equipment, and/or material provided by or through Subcontractor on or before 04/30/26 except that this document does not waive Subcontractor's lien rights to contract retainage funds held by Contractor or Owner; claims for a mechanic's lien on or entitlement to payment of any other amounts, without reservation, are hereby waived by Subcontractor.
4. Subcontractor has paid in full, except for agreed-upon retainage amounts, all of its sub-subcontractors and suppliers for labor and materials they supplied to or for the benefit of the Project more than 30 days prior to the date of the Subcontractor's signature below.
5. Subcontractor shall defend, indemnify and hold harmless the Project, the Owner, and the Contractor against all liens, suits on liens, and other claims or lawsuits, including all expenses, costs, and attorneys fees associated therewith, arising out of any labor or goods furnished by Subcontractor, or by its sub-subcontractors and suppliers of any tier, in connection with the Project.

Meyer Electric Co. Inc.

By: 

Title: President

SWORN TO before me and subscribed in my presence this 20 day of April, 2 026

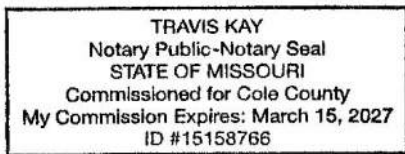

Notary Public

My Commission Expires: 3/15/2027

Lien Waiver History

Date	Company	Event
05/05/26	S. M. Wilson & Co.	Sherry Jackson approved Lien Waiver 'SMW PARTIAL conditional Dated.pdf' for Application For Payment #2 for Meyer Electric Co. Inc.
05/05/26	Meyer Electric Co. Inc.	Travis Kay uploaded Lien Waiver 'SMW PARTIAL conditional Dated.pdf' for Application For Payment #2 for Meyer Electric Co. Inc.



MEYEELE-01

S4NGARCIA

CERTIFICATE OF LIABILITY INSURANCE

DATE (MM/DD/YYYY)

2/12/2026

THIS CERTIFICATE IS ISSUED AS A MATTER OF INFORMATION ONLY AND CONFERS NO RIGHTS UPON THE CERTIFICATE HOLDER. THIS CERTIFICATE DOES NOT AFFIRMATIVELY OR NEGATIVELY AMEND, EXTEND OR ALTER THE COVERAGE AFFORDED BY THE POLICIES BELOW. THIS CERTIFICATE OF INSURANCE DOES NOT CONSTITUTE A CONTRACT BETWEEN THE ISSUING INSURER(S), AUTHORIZED REPRESENTATIVE OR PRODUCER, AND THE CERTIFICATE HOLDER.

IMPORTANT: If the certificate holder is an ADDITIONAL INSURED, the policy(ies) must have ADDITIONAL INSURED provisions or be endorsed. If SUBROGATION IS WAIVED, subject to the terms and conditions of the policy, certain policies may require an endorsement. A statement on this certificate does not confer rights to the certificate holder in lieu of such endorsement(s).

PRODUCER AssuredPartners of Missouri P.O. Box 1768 Jefferson City, MO 65102	CONTACT NAME: Noe Garcia
	PHONE (A/C, No, Ext): (573) 634-2727
	FAX (A/C, No):
	E-MAIL ADDRESS: noe.garcia@assuredpartners.com
	INSURER(S) AFFORDING COVERAGE
	INSURER A : Cincinnati Casualty Company
	INSURER B : Waypoint Mutual Group
	INSURER C :
	INSURER D :
	INSURER E :
	INSURER F :

INSURED

Meyer Electric Company, Inc.
3513 N. Ten Mile Drive
Jefferson City, MO 65109

COVERAGES

CERTIFICATE NUMBER:

REVISION NUMBER:

THIS IS TO CERTIFY THAT THE POLICIES OF INSURANCE LISTED BELOW HAVE BEEN ISSUED TO THE INSURED NAMED ABOVE FOR THE POLICY PERIOD INDICATED. NOTWITHSTANDING ANY REQUIREMENT, TERM OR CONDITION OF ANY CONTRACT OR OTHER DOCUMENT WITH RESPECT TO WHICH THIS CERTIFICATE MAY BE ISSUED OR MAY PERTAIN, THE INSURANCE AFFORDED BY THE POLICIES DESCRIBED HEREIN IS SUBJECT TO ALL THE TERMS, EXCLUSIONS AND CONDITIONS OF SUCH POLICIES. LIMITS SHOWN MAY HAVE BEEN REDUCED BY PAID CLAIMS.

INSR LTR	TYPE OF INSURANCE	ADDL INSD	SUBR WVD	POLICY NUMBER	POLICY EFF (MM/DD/YYYY)	POLICY EXP (MM/DD/YYYY)	LIMITS
A	<input checked="" type="checkbox"/> COMMERCIAL GENERAL LIABILITY <input type="checkbox"/> CLAIMS-MADE <input checked="" type="checkbox"/> OCCUR GEN'L AGGREGATE LIMIT APPLIES PER: <input checked="" type="checkbox"/> POLICY <input type="checkbox"/> PRO-JECT <input type="checkbox"/> LOC OTHER:	X	X	EPP 0557901	12/31/2025	12/31/2026	EACH OCCURRENCE \$ 1,000,000 DAMAGE TO RENTED PREMISES (Ea occurrence) \$ 500,000 MED EXP (Any one person) \$ 10,000 PERSONAL & ADV INJURY \$ 1,000,000 GENERAL AGGREGATE \$ 2,000,000 PRODUCTS - COMP/OP AGG \$ 2,000,000 \$
A	<input checked="" type="checkbox"/> AUTOMOBILE LIABILITY <input checked="" type="checkbox"/> ANY AUTO OWNED AUTOS ONLY <input type="checkbox"/> SCHEDULED AUTOS <input type="checkbox"/> HIRED AUTOS ONLY <input type="checkbox"/> NON-OWNED AUTOS ONLY	X	X	EBA 0557901	12/31/2025	12/31/2026	COMBINED SINGLE LIMIT (Ea accident) \$ 1,000,000 BODILY INJURY (Per person) \$ BODILY INJURY (Per accident) \$ PROPERTY DAMAGE (Per accident) \$ \$
A	<input checked="" type="checkbox"/> UMBRELLA LIAB <input checked="" type="checkbox"/> OCCUR <input type="checkbox"/> EXCESS LIAB <input type="checkbox"/> CLAIMS-MADE DED RETENTION \$	X	X	EPP 0557901	12/31/2025	12/31/2026	EACH OCCURRENCE \$ 10,000,000 AGGREGATE \$ 10,000,000 \$
B	WORKERS COMPENSATION AND EMPLOYERS' LIABILITY ANY PROPRIETOR/PARTNER/EXECUTIVE OFFICER/MEMBER EXCLUDED? (Mandatory in NH) <input checked="" type="checkbox"/> Y / N If yes, describe under DESCRIPTION OF OPERATIONS below	N	N/A	WC100-0000793-2026A	1/1/2026	1/1/2027	<input checked="" type="checkbox"/> PER STATUTE <input type="checkbox"/> OTH-ER E.L. EACH ACCIDENT \$ 1,000,000 E.L. DISEASE - EA EMPLOYEE \$ 1,000,000 E.L. DISEASE - POLICY LIMIT \$ 1,000,000
A	Install / Bldg Risk-			EPP 0557901	12/31/2025	12/31/2026	Job Limit \$ 2,000,000
A	Equipment Floater			EPP 0557901	12/31/2025	12/31/2026	Limit w/\$1000 ded \$ 1,000,000

DESCRIPTION OF OPERATIONS / LOCATIONS / VEHICLES (ACORD 101, Additional Remarks Schedule, may be attached if more space is required)
Professional Liability \$2M each occurrence \$2M aggregate, Policy #ANE5438913.25 Effective Date 05/01/25 to 05/01/26. Brokerage is AmWins, Carrier is Hiscox Insurance Co.

Pollution Liability \$2M each occurrence, \$2M aggregate, Policy #EGL0011352 Effective 12/31/25 to 12/31/26. Brokerage is Breckenridge, Carrier is Mt. Hawley Insurance Company.

Job Name: 0125005.00 Hallsville 2025 Bond Issue; Meyer Job #7180. S.M. Wilson & Co. and Hallsville School District are additional insureds on a primary non SEE ATTACHED ACORD 101

CERTIFICATE HOLDER

CANCELLATION

S.M. Wilson & Co. 2185 Hampton Avenue Saint Louis, MO 63139	SHOULD ANY OF THE ABOVE DESCRIBED POLICIES BE CANCELLED BEFORE THE EXPIRATION DATE THEREOF, NOTICE WILL BE DELIVERED IN ACCORDANCE WITH THE POLICY PROVISIONS.
	AUTHORIZED REPRESENTATIVE 



ADDITIONAL REMARKS SCHEDULE

AGENCY AssuredPartners of Missouri		NAMED INSURED Meyer Electric Company, Inc. 3513 N. Ten Mile Drive Jefferson City, MO 65109	
POLICY NUMBER SEE PAGE 1			
CARRIER SEE PAGE 1	NAIC CODE SEE P 1	EFFECTIVE DATE: SEE PAGE 1	

ADDITIONAL REMARKS

THIS ADDITIONAL REMARKS FORM IS A SCHEDULE TO ACORD FORM,
FORM NUMBER: ACORD 25 FORM TITLE: Certificate of Liability Insurance

Description of Operations/Locations/Vehicles:

-contributory basis with a waiver of subrogation in their favor on the general liability and auto liability with respects to work performed by the insured when required by written contract. A 30-day notice of cancellation applies. Excess/Umbrella Liability follows form. No deductible applies on umbrella. Blanket WC Notice of Cancellation applies. Waiver of Subrogation does not apply to work comp in the State of Missouri

APPLICATION FOR PAYMENT

To: S. M. Wilson & Co.
2185 Hampton Ave
Saint Louis, MO 63139

From: Jeff Schnieders Construction Company
1314 Highway 179
Jefferson City, MO 65109

Contract For: 0125005.00009 - Demo, Earthwork, Site
Utilities

Project: Hallsville 2025 Bond Issue

Application No.: 2
Period To: 04/30/26
Application Date: 04/23/26
Project No.: 0125005.00
Contract Date: 02/23/26
Commitment: 0125005.00009

1. ORIGINAL CONTRACT AMOUNT	\$512,513.00
2. NET CHANGE BY CHANGE ORDERS	\$3,070.00
3. CONTRACT SUM TO DATE	\$515,583.00
4. TOTAL COMPLETED AND STORED TO DATE (Column G)	\$180,107.80
5. RETAINAGE	
5.00% of Completed Work	\$9,005.39
(Columns D + E)	
5.00% of Stored Materials	-
(Columns F)	
Total Retainage	\$9,005.39
(Line 5a + Line 5b OR Sum of Column I)	
6. TOTAL EARNED LESS RETAINAGE	\$171,102.41
(Line 4 less Line 5 Total)	
7. LESS PRIOR CERTIFICATES FOR PAYMENT	\$93,933.10
(Line 6 from prior Certificate)	
8. CURRENT PAYMENT DUE	\$77,169.31
9. BALANCE TO FINISH, INCLUDING RETAINAGE	\$344,480.59
(Line 3 less Line 6)	

The undersigned Contractor certifies that to the best of the Contractor's knowledge, information and belief the Work covered by this Application for Payment has been completed in accordance with the Contract Documents, that all amounts have been paid by the Contractor for Work for which previous Certificates for Payment were issued and payments received from the Owner, and that current payment shown herein is now due.

CONTRACTOR:

By: Mindy Bax Date: 04/23/26

State Of: _____

County Of: _____

Subscribed and sworn to before me this _____ day of _____

Notary Public: _____

My commission expires: _____

ARCHITECTS CERTIFICATE FOR PAYMENT

In accordance with the Contract Documents, based on the on-site observations and the data compromising this application, the Architect certifies to the owner that to the best of the Architects knowledge, information and belief the Work under the Architect's Contract has progressed as indicated, the quality of Work is in accordance with the Contract Documents, and the Contractor is entitled to payment of the AMOUNT CERTIFIED.

AMOUNT CERTIFIED \$77,169.31

(Attach explanation if amount certified differs from the amount applied for. Initial all figures on the Application for Payment and on the Continuation sheet that are changes to conform to the amount certified.)

ARCHITECT:

By: _____ Date: _____

The Certificate is not negotiable. The AMOUNT CERTIFIED is payable only to the Contractor named herein. Issuance, payment and acceptance of payment are without prejudice to any rights of the Owner or Contractor under this Contract.

CHANGE ORDER SUMMARY	ADDITIONS	DEDUCTIONS
Total changes approved in previous months	\$0.00	\$0.00
Total approved this month	\$3,070.00	\$0.00
TOTALS	\$3,070.00	\$0.00
NET CHANGES by Change Orders		\$3,070.00

CONTINUATION SHEET

APPLICATION AND CERTIFICATION FOR PAYMENT,
 containing Contractor's signed Certification is attached.
 In tabulations below, amounts are stated to the nearest dollar.

APPLICATION NO.: 2

APPLICATION DATE: 04/23/26

PERIOD TO: 04/30/26

PROJECT NO.: 0125005.00

Jeff Schnieders Construction Company

A ITEM NUM	B DESCRIPTION OF WORK	C SCHEDULED VALUE	D WORK COMPLETED		F MATERIALS PRESENTLY STORED (NOT IN D OR E)	G		H BALANCE TO FINISH (C - G)	I RETAINAGE (IF VARIABLE RATE)
			FROM PREVIOUS APPLICATION (D+E)	THIS PERIOD		TOTAL COMPLETED AND STORED TO DATE	% (G ÷ C)		
1	Construction Entrance & Temp Gravel	\$20,000.00	\$2,000.00	-	-	\$2,000.00	10.00%	\$18,000.00	\$100.00
2	Mobilization	\$9,000.00	\$4,500.00	\$2,250.00	-	\$6,750.00	75.00%	\$2,250.00	\$337.50
3	Layout	\$9,000.00	\$1,800.00	\$2,250.00	-	\$4,050.00	45.00%	\$4,950.00	\$202.50
4	SWPP	\$11,000.00	\$5,500.00	\$1,650.00	-	\$7,150.00	65.00%	\$3,850.00	\$357.50
5	Seeding & Erosion Blankets	\$36,000.00	-	-	-	-	-	\$36,000.00	-
6	Removals & Site Prep: Phase 1	\$68,000.00	\$51,000.00	\$13,600.00	-	\$64,600.00	95.00%	\$3,400.00	\$3,230.00
7	Removals & Site Prep: Phase 2	\$25,000.00	-	-	-	-	-	\$25,000.00	-
8	Site Exc & Fill: Phase 1	\$55,513.00	\$8,326.95	\$24,980.85	-	\$33,307.80	60.00%	\$22,205.20	\$1,665.39
9	Site Exc & Fill: Phase 2	\$26,500.00	-	-	-	-	-	\$26,500.00	-
10	Dugout Pads & Bullpens	\$8,500.00	-	-	-	-	-	\$8,500.00	-
11	Finish Grade: Field	\$43,000.00	-	\$10,750.00	-	\$10,750.00	25.00%	\$32,250.00	\$537.50
12	Finish Grade: Parking lot & Walks	\$38,000.00	-	-	-	-	-	\$38,000.00	-
13	Finish Grade: Entrance Drive	\$10,000.00	\$5,000.00	\$5,000.00	-	\$10,000.00	100.00%	-	\$500.00
14	Finish Yard including topsoil	\$60,000.00	-	-	-	-	-	\$60,000.00	-
15	Storm Sewer	\$83,000.00	\$20,750.00	\$20,750.00	-	\$41,500.00	50.00%	\$41,500.00	\$2,075.00
16	Rip Rap	\$10,000.00	-	-	-	-	-	\$10,000.00	-
2	Earthwork, Demolition, Site Utilities (CO #1)	\$3,070.00	-	-	-	-	-	\$3,070.00	-
PAYMENT TOTALS		\$515,583.00	\$98,876.95	\$81,230.85	-	\$180,107.80	34.93%	\$335,475.20	\$9,005.39

Audit Trail

Project: Hallsville 2025 Bond Issue (0125005.00)

From: Jeff Schnieders Construction Company

Date	User	Company	Event
05/05/26 13:25 GMT	Sherry Jackson	S. M. Wilson & Co.	Sherry Jackson approved Lien Waiver '2nd Tier Lien Waiver Supplier Partial.pdf' for Application For Payment #2 for Jeff Schnieders Construction Company (County Materials)
05/04/26 19:02 GMT	GCPay Support	GCPay	Lien Waiver recieved by email / fax
05/04/26 17:58 GMT	Patrick Aylesworth	S. M. Wilson & Co.	Patrick Aylesworth sent Lien Waiver '2nd Tier Lien Waiver Supplier Partial.pdf' for Application For Payment #2 for Jeff Schnieders Construction Company (Cooper Sales & Welding)
05/04/26 17:58 GMT	Patrick Aylesworth	S. M. Wilson & Co.	Patrick Aylesworth sent Lien Waiver '2nd Tier Lien Waiver Supplier Partial.pdf' for Application For Payment #2 for Jeff Schnieders Construction Company (County Materials)
05/04/26 17:58 GMT	Patrick Aylesworth	S. M. Wilson & Co.	Patrick Aylesworth approved Application For Payment #2 for Jeff Schnieders Construction Company
04/29/26 13:11 GMT	Sherry Jackson	S. M. Wilson & Co.	Sherry Jackson approved Lien Waiver 'SMW PARTIAL conditional Dated.pdf' for Application For Payment #2 for Jeff Schnieders Construction Company
04/29/26 13:10 GMT	Sherry Jackson	S. M. Wilson & Co.	Sherry Jackson approved Application For Payment #2 for Jeff Schnieders Construction Company
04/29/26 13:09 GMT	Moriah Ellis	S. M. Wilson & Co.	Moriah Ellis approved Application For Payment #2 for Jeff Schnieders Construction Company
04/23/26 15:33 GMT	Mindy Bax	Jeff Schnieders Construction Company	Mindy Bax submitted Application For Payment #2 for Jeff Schnieders Construction Company
04/23/26 15:33 GMT	Mindy Bax	Jeff Schnieders Construction Company	Mindy Bax uploaded Lien Waiver 'SMW PARTIAL conditional Dated.pdf' for Application For Payment #2 for Jeff Schnieders Construction Company
04/23/26 15:20 GMT	Mindy Bax	Jeff Schnieders Construction Company	Marked off checklist item 'All required documents for stored materials (if applicable) billed in this period's pay application have been uploaded. ' on Application For Payment #2 for Jeff Schnieders Construction Company
04/23/26 15:20 GMT	Mindy Bax	Jeff Schnieders Construction Company	Marked off checklist item 'All of the lower tier subcontractors & suppliers with the required information have been submitted accurately in the Liabilities section.' on Application For Payment #2 for Jeff Schnieders Construction Company
04/23/26 15:20 GMT	Mindy Bax	Jeff Schnieders Construction Company	Mindy Bax certified information on the liabilities tab.
04/23/26 15:15 GMT	Mindy Bax	Jeff Schnieders Construction Company	Mindy Bax created Application For Payment #2 for Jeff Schnieders Construction Company

STATE OF: MO

JOB # 0125005.00

COUNTY OF: Cole

PAY APPLICATION # 2

SUBCONTRACTOR'S CONDITIONAL PARTIAL WAIVER OF LIEN

Mindy Bay of Jeff Schnieders Construction Company
("Subcontractor") being first duly sworn, states as follows:

1. I am the Bookkeeper (title and/or position) of Subcontractor, and am familiar with the facts stated herein.
2. Subcontractor has provided to or through S. M. Wilson & Co. ("Contractor") certain labor, supplies, materials, equipment and/or other items for use in the construction of improvements located at Hallsville 2025 Bond Issue , 421 E. Highway 124, Hallsville, MO 65255 (the "Project") owned by HALLSVILLE R-IV SCHOOL DISTRICT ("Owner").
3. Upon receipt by the undersigned of a check payable to the Subcontractor, and when the check has been properly endorsed and has been paid by the bank on which it is drawn Subcontractor hereby waives all rights to a mechanic's lien or to any other claim against the Project, or any improvements thereon, for labor, supplies, equipment, and/or material provided by or through Subcontractor on or before 04/30/26 except that this document does not waive Subcontractor's lien rights to contract retainage funds held by Contractor or Owner; claims for a mechanic's lien on or entitlement to payment of any other amounts, without reservation, are hereby waived by Subcontractor.
4. Subcontractor has paid in full, except for agreed-upon retainage amounts, all of its sub-subcontractors and suppliers for labor and materials they supplied to or for the benefit of the Project more than 30 days prior to the date of the Subcontractor's signature below.
5. Subcontractor shall defend, indemnify and hold harmless the Project, the Owner, and the Contractor against all liens, suits on liens, and other claims or lawsuits, including all expenses, costs, and attorneys fees associated therewith, arising out of any labor or goods furnished by Subcontractor, or by its sub-subcontractors and suppliers of any tier, in connection with the Project.

Jeff Schnieders Construction Company

By: Mindy Bay

Title: Bookkeeper

SWORN TO before me and subscribed in my presence this 23 day of April, 2026

Hannah Corrine Hayward
Notary Public

My Commission Expires: 04.14.28



Lien Waiver History

Date	Company	Event
04/29/26	S. M. Wilson & Co.	Sherry Jackson approved Lien Waiver 'SMW PARTIAL conditional Dated.pdf' for Application For Payment #2 for Jeff Schnieders Construction Company
04/23/26	Jeff Schnieders Construction Company	Mindy Bax uploaded Lien Waiver 'SMW PARTIAL conditional Dated.pdf' for Application For Payment #2 for Jeff Schnieders Construction Company

V. Project Schedule Update:

Monthly Project Schedule Update:

All Purpose Field & Parking Lot:

Weather Days:

- 30.5 days to-date

All Purpose Field Progress:

- Continued placing fill on the Northwest side of the site and on new field area
- Finished installing storm structures and pipe on West side of the site

Entrance Drive Lane Progress:

- Lowered Bluebird fiber line
- Continued grading at drive entrance
- Laid rock and fabric on about 650 ft of entrance & drive lane

Parking Lot Progress:

- Began removing fence posts at old baseball field

Classroom Addition & Secure Entry Doors:

Weather Days:

- 5 days

Classroom Addition Progress:

- N/A - plan to begin demo week of 5/26

Secure Entry Door Progress:

- N/A - plan to begin demo week of 6/9

VI. Construction Activity Update & Photos:



Stripping Topsoil at the Field



Grading at the Field



Stripping Topsoil at the Drive Lane



Beginning to Grade the Drive Lane



Fine Grading at the Drive Lane



Fabric and Rock at the Drive Lane



EastSide / Upper Part of the Drive Lane



Lowering Fiber Line at Drive Lane



Aerial Photo of Site on April 9, 2026



Aerial Photo of Site on May 14, 2026

II. Board Action Items & Approval of Progress Report:

Board of Education Action Items:

1. We request the school board's review and approval for Change Order 010 - 012 as part of the approval of this report.
2. We request the school board review and approve the April '26 monthly payment application

Hallsville District Administrative Team and Construction Manager request approval of Progress Report #3, and action items listed above as presented and as further discussed at the May 26th, 2026 School Board Meeting.